

SYGNATECH, INC.

3215 Golf Rd, #266, Delafield, WI 53018 USA
Phone: (262) 646-2464 Fax: (262) 646-2392

Magnetic Proximity Switch MSW-L (Latching Type) DC/AC Version

CE Classification: M2C235AU9

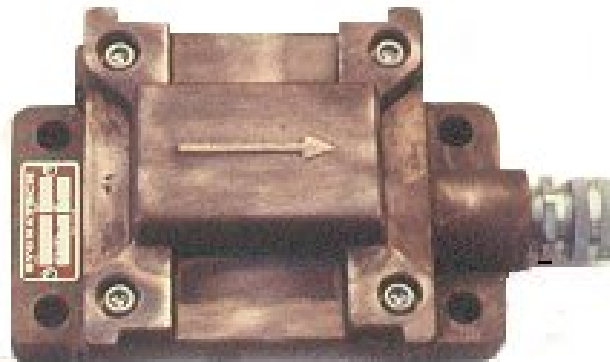

GENERAL DESCRIPTION

Magnetic proximity switches are used to detect the position of a moving object without mechanical actuation. The MSW-L switches have been specially designed for mine hoist applications.

The distinctive feature of MSW-L switches is their high sensitivity, allowing them to be activated from a relatively long distance from the actuating magnet. The switch also has a heavy duty, corrosion resistant red brass enclosure to ensure reliability against the harsh conditions normally present in mining applications.

Switch type **MSW-L** offers “latching” type operation. It will stay either open or closed after being subjected to a magnetic field. Its state (open/closed) is maintained even after power supply failure. These are ideal for detecting the position of a mine hoist conveyance in the shaft.

From the connection point of view, the MSW-L switch operates as ordinary contact with 2 terminals.

The MSW switches can operate with different types of actuating magnets. For mine hoist applications, we recommend Sygnatech MM-1 magnets. They are flat, relatively thin, and easy to mount on the side of the conveyance. The standard version is type MM-1-S, which has the South pole facing the switch.

DIMENSION DRAWINGS

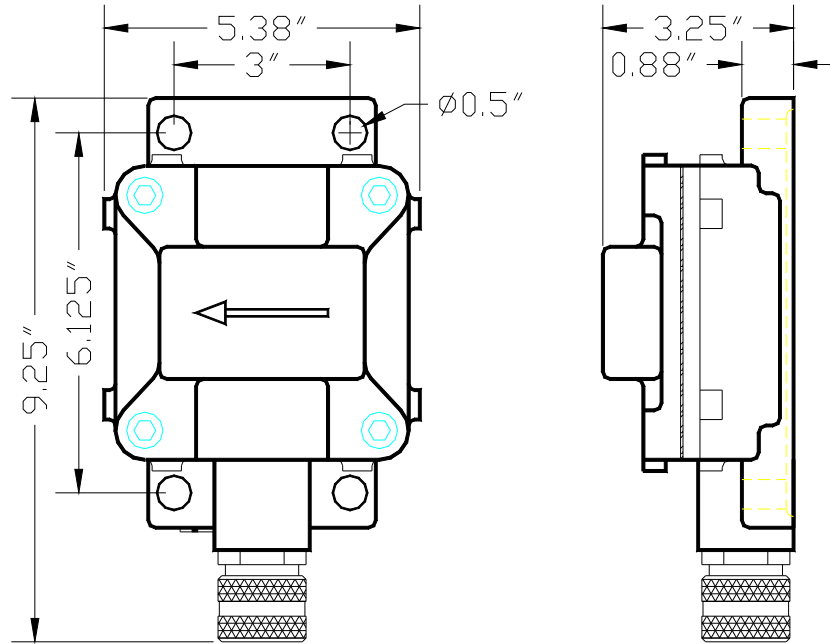

SWITCH MSW-L

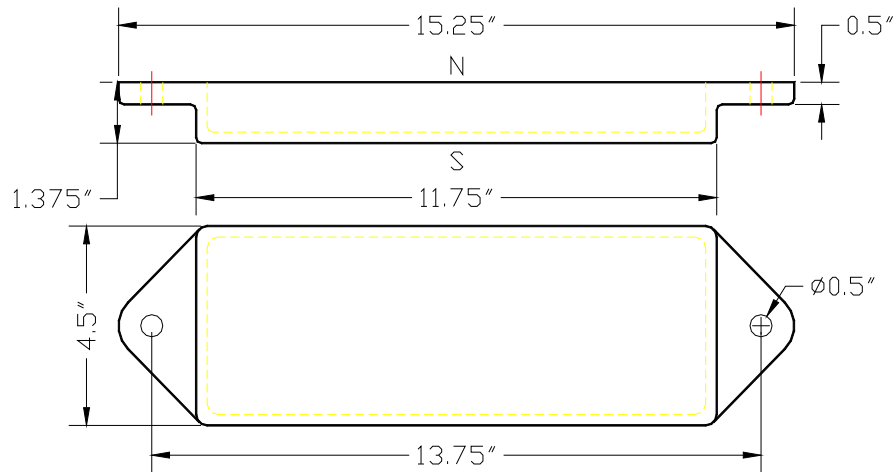

MAGNET MM-1-S

Note: The same magnet is available with magnetic North pole on the operating side. Its designation is MM-1-N

PRINCIPLE OF OPERATION

The state of the latching proximity switch (open or close) depends on the direction of the magnetic field the switch was subjected to. This principle makes it ideal for determination of the position of the object fitted with permanent magnet. A typical example is a mine hoist conveyance in the shaft. When the conveyance is above the switch (passed the switch on the way up) the switch is in one state (for example closed) but when the conveyance is below the switch (passed the switch on the way down) the state of the switch changes (in this example from closed to open).

The operation principle of the MSW-L switch is shown below.

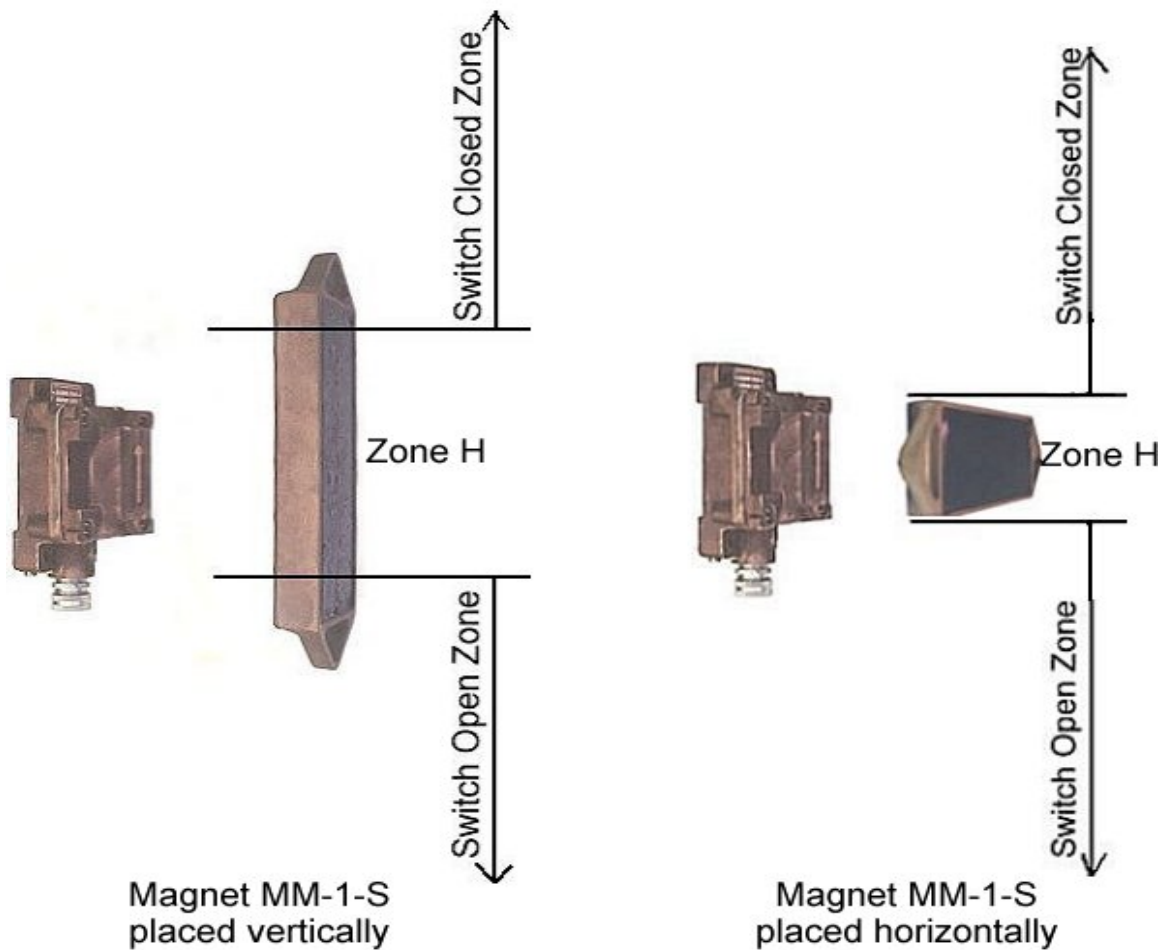

In Zone H, the switch status could be closed or open, depending on the direction of movement. If the magnet is moving down the switch is closed in Zone H and opens when the magnet reaches "Switch Open Zone". If the magnet is moving up, the switch is open in Zone H and closes when the magnet reaches "Switch Closed Zone". Note, that the "undefined" Zone H is wider if the magnet is oriented vertically. So if a narrow Zone H is required, the magnet should be mounted in a horizontal position.

PRINCIPLE OF OPERATION(cont'd)

Some features of the MSW-L latching switch:

- The magnet should travel along the arrow marked on the cover of the switch. The switch cover can be mounted in 4 positions, 90 degrees apart. This allows matching the existing position of the switch to the direction of travel and polarity of the magnet.
- The switch state (open, closed) depends on the polarity of the magnet and direction of its travel. If the South Pole of the magnet is facing the switch, the switch closes when the magnet passes it in the direction pointed by the arrow on the switch cover. When the magnet passes the switch in other direction it opens.
- Passing the switch several times in the same direction (by magnet of the same polarity) does not change the state of the switch.
- Reversing the action of the switch (opening/closing) for the same direction of magnet travel can be done either by turning the switch cover of 180 degrees or by reversing the polarity of the magnet.
- The advantage of latching switches is that their state (open/closed) indicates that the conveyance has passed the switch and is above or below. Also, latching action allows easy assessment of the proper switch operation, which is rather difficult in case of pulse switch and fast speed conveyance (very short pulse duration).
- If the path of the magnet is very close to the switch it might produce additional short pulse when the magnet is in the vicinity of the switch. This however does not result in an incorrect state after the magnet passed the switch - its state will always be as described above.

TECHNICAL DATA

Type of operation	Latching (bistable)
Operating distance with MM-1 magnet	10 inch (254 mm) - standard, 15 inch (381 mm) - sensitive
Output contact	Reed Switch
Number of connecting wires	2
Max. size of connecting wires	12 AWG (3.3 mm ²)
Rated voltage	120 VDC/AC
Rated current	0.2 A DC/AC
Maximum switching current	1.0 A DC/AC
Maximum switching power	25 W (DC), 25 VA (AC)
Weight (approx)	14.8 lbs (6.7 kg)
Dimensions	9.3x5.4x3.2 inch (235x137x83 mm)
Environmental conditions:	
Ambient temperature	-40 to +170 deg F (-40 to +76 deg C)
Humidity	0 – 100 %
Altitude	-15,000 ft to + 20,000 ft (-4572m to +6096 m)

ELECTRICAL CONNECTIONS

Basic Circuit Diagram

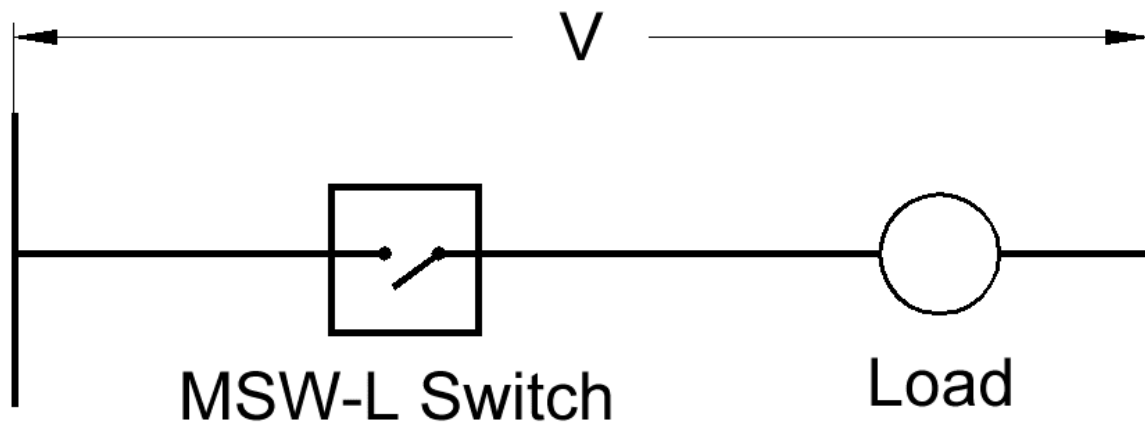

Remarks:

- With the inductive load and AC application, it is advisable to have a voltage arrester across the load in form of varistor or RC-type suppressor.
- With the inductive load and DC application, it is advisable to have a voltage arrester across the load in form of varistor or free-wheeling diode.

INSTALLATION INSTRUCTIONS

Mechanical Installation:

The switch should be mounted using the 4 mounting holes on its base. The surrounding of the switch, especially the area between the switch and the passing magnet should be free from the ferromagnetic material (steel, iron) which could attract the magnetic flux from the magnet thus deflecting it from the switch and reducing its sensitivity.

The switch should be mounted in the vicinity of the passing magnet, with the arrow on the cover parallel to the movement path of the magnet.

For reliable operation the distance between the surface of the switch and the magnet should be about 50 to 90% of the operating distance of the switch. For standard MSW-L switch with operating distance of with 10 inches (254 mm), this relates to about 5 - 9 inches (127 - 228 mm). For the sensitive version, this distance would be 7.5 - 13.5 inches (190 – 343 mm).

The position of the switch base should be either vertical (with the cable entry from the bottom) or horizontal. For convenience, the cover of the switch is fixed to the base with 4 mounting screws and can be mounted in 4 directions to match the path of the actuating magnet and required operation of the switch (opening or closing)

The MSW-L switches can operate with different types of actuating magnets. For mine hoist applications, however, we recommend using Sygnatech MM-1 magnets. They are flat, relatively thin, and easy to mount on the side of the conveyance. Similarly as the switch, the magnet should not have any ferromagnetic material in front of or on its side. However, if magnet MM-1 is used, it can be mounted directly on the conveyance or on a non-magnetic plate mounted on the surface of the steel conveyance. The non-magnetic plate prevents magnetization of the conveyance below or above the magnet, thus eliminating the possibility of false action of the switch.

The switch state (open, closed) depends on the polarity of the magnet and direction of its travel. If the South Pole of the magnet is facing the switch (MM-1-S), the switch closes when the magnet passes it in the direction pointed by the arrow on the switch cover. When the magnet passes the switch in other direction it opens.

In applications where the switch can be subjected to falling rocks it is advisable to provide a protective shield for the switch and connecting cable in form of a steel rod or beam, mounted minimum 20 inches (500 mm) above the switch.

INSTALLATION INSTRUCTIONS

Electrical Installation:

1. The electrical installation should follow local electrical codes and regulations.
2. The switch connections are done by removing the switch cover and connecting the cable conductors to 2 switch wires using screw type terminals inside the switch. Maximum size of cable conductor - AWG12 (3.3 mm²). It is not important which wire of the switch is connected to the load. Ground connection should be done using grounding screw on the switch body, inside the switch.
3. After connecting the wires, the cover of the switch has to be remounted on the switch base. **Make sure connecting wires do not get between the cover and the flat surface of the switch base.**
4. The cover should be aligned with the arrow pointing the proper direction as described in Principal of Operation. The four mounting bolts should be tightened with a torque of about 3 ft-lbs (4 Nm).
5. In a wet environment, even though the switch is sealed, there is a possibility of a moisture development inside the switch. Adequate protection in such case is provided by covering the connecting points of switch wires and cable conductors with Vaseline see picture below.

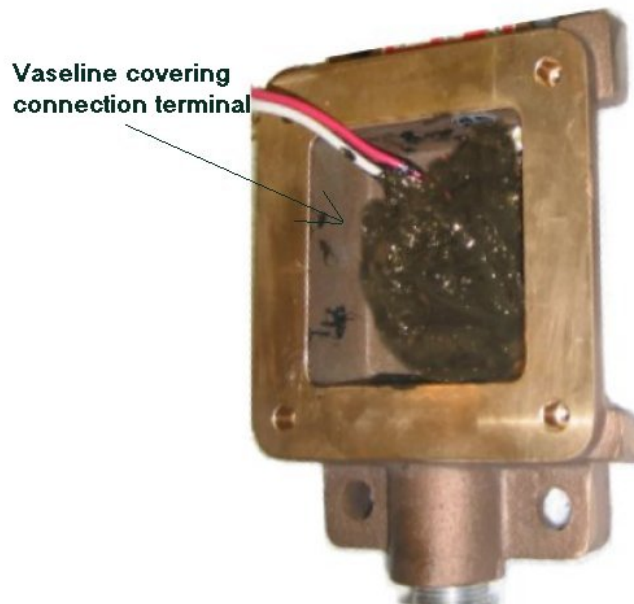

MAINTENANCE INSTRUCTIONS

The switch is basically maintenance free. Periodical visual inspections have to be done in order to check the integrity of the switch (integrity of connecting cable, integrity of the enclosure, integrity of the actuating magnet). The frequency of these checks depends on the local condition the switch operates in.

If the supply voltage of the switch does not have ground fault detection, periodical insulation test should be conducted. It is recommended to use insulation tester with the voltage between 250V and 500 V. The frequency of this test depends on the local conditions and regulations, but it is suggested to do it at least once per year.